

ED2171WA
ED2671WA



EN Dehumidifier

User Manual

2

TC 除濕機

使用手冊

20

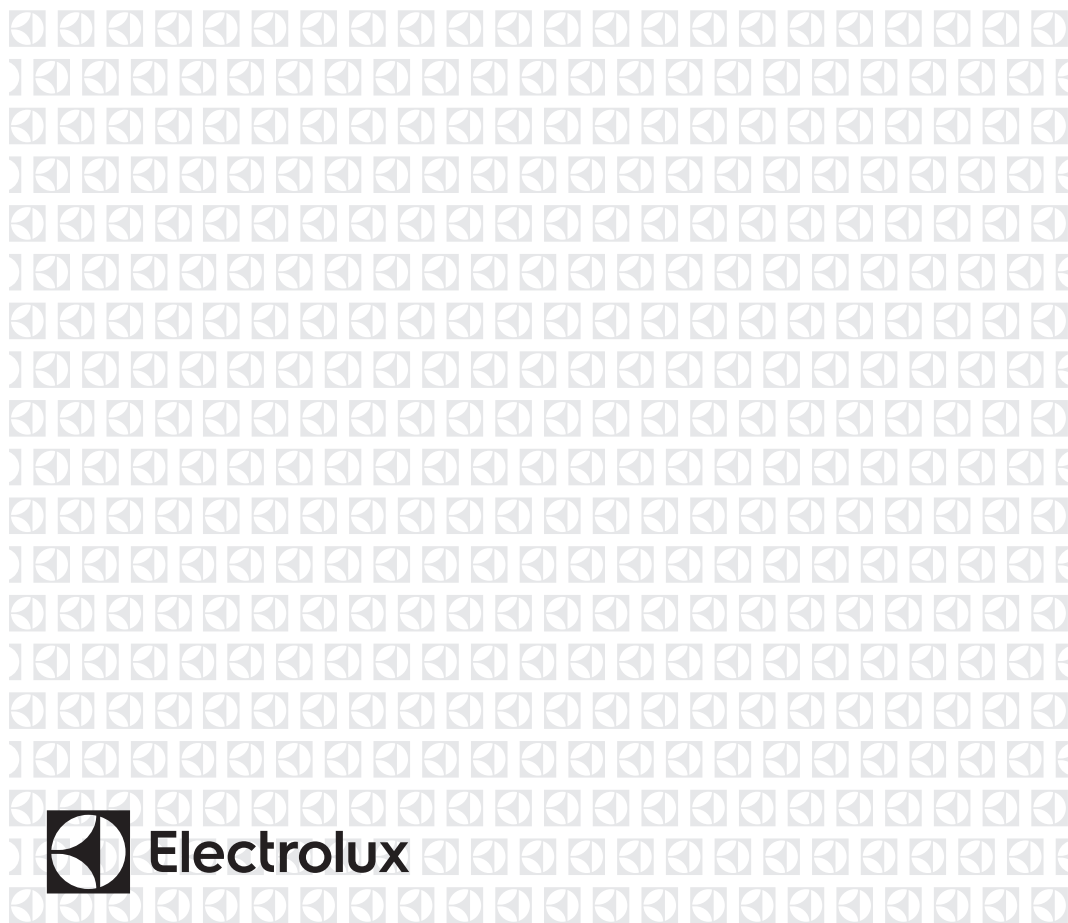

Electrolux

CONTENTS

- 1. SAFETY INFORMATION 3
- 2. PRODUCT DESCRIPTION 11
- 3. BEFORE FIRST USE 13
- 4. OPERATING INSTRUCTIONS 13
- 5. CARE AND CLEANING 17
- 6. WHAT TO DO IF... 18
- 7. ENVIRONMENT CONCERNS 19

WE'RE THINKING OF YOU

Thank you for purchasing an Electrolux appliance. You've chosen a product that brings with it decades of professional experience and innovation. Ingenious and stylish, it has been designed with you in mind. So whenever you use it, you can be safe in the knowledge that you'll get great results every time.

Welcome to Electrolux.

Visit our website to:



Get usage advice, brochures, trouble-shooting, service information:
www.electrolux.com



Register your product for better service:
www.registerelectrolux.com



Buy Accessories, Consumables and Original spare parts for your appliance:
www.electrolux.com/shop

CUSTOMER CARE AND SERVICE

Always use original spare parts.

When contacting our Authorised Service Centre, ensure that you have the following data available: Model, PNC, Serial Number.

The information can be found on the rating plate.

Symbols in the instruction:

 Warning / Caution-Safety information.

 General information and tips.

 Environmental information.





Subject to change without notice.

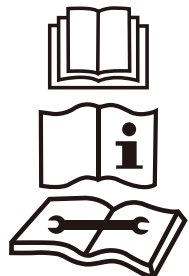

Caution, risk of fire



1. SAFETY INFORMATION

Symbol	Note	Explanation
	WARNING	This symbol shows that this appliance uses a flammable refrigerant. If the refrigerant is leaked and exposed to an external ignition source, there is a risk of fire.
	CAUTION	This symbol shows that the operation manual should be read carefully.
	CAUTION	This symbol shows that a service personnel should be handling this equipment with reference to the installation manual.
	CAUTION	This symbol shows that information is available such as the operating manual or installation manual.

Before the installation and use of the appliance, carefully read the supplied instructions. The manufacturer is not responsible for any injuries or damage that are the result of incorrect installation or usage. Always keep the instructions in a safe and accessible location for future reference.

WARNING

For Your Safety

- Do not store or use gasoline or other flammable vapors and liquids in the vicinity of this or any other appliance. Read product labels for flammability and other warnings.
- Discard water from bucket. Water is not potable and cannot be used for drinking.

Electrical Information

- For your safety and protection, this dehumidifier is equipped with a three-prong grounding plug on the power cord. Do not, under any circumstances, cut or remove the round ground prong from the plug.
- Your dehumidifier must be plugged directly into a properly grounded and polarized three-prong receptacle. If the wall receptacle you intend to use will not

accept a three-prong plug, or if you are not sure the outlet is adequately grounded or protected by a time delay fuse or circuit breaker, have a qualified electrician install the proper outlet according to the National Electrical Code and applicable local codes and ordinances. Do not use an extension cord or an adapter plug.

- Never unplug the dehumidifier by pulling on the power cord. Always grip the plug firmly and pull straight out from the receptacle.
- Do not pinch, bend, or knot the power cord.

Child Safety Precautions

- Destroy the carton, plastic bags, and any packing materials immediately after the dehumidifier is unpacked. Children should never use these items for play.

- Do not leave children unattended in an area where the appliance is operating. Do not allow them to sit or stand on the appliance.
- This appliance is not intended for use by persons (including children) with reduced physical, sensory or mental capabilities or lack of experience and knowledge, unless they have been given supervision or instruction concerning use of the appliance by a person responsible for their safety.
- Children should be supervised to ensure that they do not play with the appliance.

DANGER

Avoid Serious Injury or Death

- This dehumidifier contains no user-serviceable parts. Always call an authorized Electrolux servicer for repairs.
- Do not insert or place fingers or objects into the air discharge area or back grille of the unit.
- Do not start or stop the dehumidifier by unplugging the power cord or turning off the power at the electrical box.
- Do not cut or damage the power cord. Do not pull on the power cord.
- If the power cord is damaged, it should only be replaced by an authorized Electrolux servicer.
- In the event of a malfunction (sparks, burning smell, etc.), immediately stop the operation, disconnect the power cord, and call an authorized Electrolux servicer.
- Do not operate the dehumidifier with wet hands. Do not drink any water from the dehumidifier.
- If the supply cord is damaged, it must be replaced by the manufacturer, its service agent or similarly qualified persons in order to avoid a hazard.
- The appliance shall be installed in accordance with national wiring regulations.



CAUTION

Avoid Injury or damage to the unit or other property

- Do not direct airflow at fireplaces or other heat related sources as this could cause flare ups.
- Do not climb on or place objects on the unit. Do not hang objects off the unit.
- Do not place containers with liquids on the unit.
- Turn off the dehumidifier at the power source when it will not be used for an extended period of time.
- Operate the unit with air filter in place.
- Do not block or cover the intake grille, discharge area and outlet ports.
- Ensure that any electrical/electronic equipment is one yard away from the unit.
- Do not use or store flammable gases near the unit.



WARNING

Avoid fire hazard or electric shock. Do not use an extension cord or an adaptor plug. Do not remove any prong from the power cord.

Grounding type wall receptacle



Do not, under any circumstances, cut, remove, or bypass the grounding prong.

Power supply cord with 3-prong grounding plug

PLEASE NOTE: CHECK THE PLATE FOR THE TYPE OF REFRIGERANT GAS USED IN YOUR APPLIANCE.



WARNING

FOR FLAMMABLE REFRIGERANT

- Servicing shall only be performed as recommended by the equipment manufacturer. Maintenance and repair requiring the assistance of other skilled personnel shall be carried out under the supervision of the person competent in the use of flammable refrigerants.
- DO NOT modify the length of the power cord or use an extension cord to power the unit.
- DO NOT share a single outlet with other electrical appliances. Improper power supply can cause fire or electrical shock.
- Please follow the instruction carefully to handle, install, clear, service the air conditioner to avoid any damage or hazard.
- Flammable Refrigerant R32 is used within air conditioner. When maintaining or disposing the air conditioner, the refrigerant (R32) shall be recovered properly, shall not discharge to air directly.
- Compliance with national gas regulations shall be observed.
- Keep ventilation openings clear of obstruction.
- The appliance shall be stored so as to prevent mechanical damage from occurring.
- A warning that the appliance shall be stored in a well-ventilated area where the room size corresponds to the room area as specified for operation.
- Any person who is involved with working on or breaking into a refrigerant circuit should hold a current valid certificate from an industry-accredited assessment authority, which authorises their competence to handle refrigerants safely in accordance with an industry recognised assessment specification.

Examples for such working procedures are:

- breaking into the refrigerating circuit;
- opening of sealed components;
- opening of ventilated enclosures.

- No any open fire or device like switch which may generate spark/arcing shall be around air conditioner to avoid causing ignition of the flammable refrigerant used. Please follow the instruction carefully to store or maintain the air conditioner to prevent mechanical damage from occurring.
- Do not use means to accelerate the defrosting process or to clean, other than those recommended by the manufacturer.
- The appliance shall be stored in a room without continuously operating ignition sources (for example: open flames, an operating gas appliance) and ignition sources or (for example: an operating electric heater) close to the appliance.
- Do not pierce or burn.
- Be aware that the refrigerants may not contain an odour.

1. Transport of equipment containing flammable refrigerants.

See transport regulations.

2. Marking of equipment using signs

See local regulations.

3. Disposal of equipment using flammable refrigerants

See national regulations.

4. Storage of equipment/appliances

The storage of equipment should be in accordance with the manufacturer's instructions.

5. Storage of packed (unsold) equipment

Storage package protection should be constructed such that mechanical damage to the equipment inside the package will not cause a leak of the refrigerant charge. The maximum number of pieces of equipment permitted to be stored together will be determined by local regulations.

6. Information on servicing

a) Checks to the area

Prior to beginning work on systems containing flammable refrigerants, safety checks are necessary to ensure that the risk of ignition is minimised. For repair to the refrigerating system, the following precautions shall be complied with prior to conducting work on the system.

b) Work procedure

Work shall be undertaken under a controlled procedure so as to minimise the risk of a flammable gas or vapour being present while the work is being performed.

c) General work area

All maintenance staff and others working in the local area shall be instructed on the nature of work being carried out. Work in confined spaces shall be avoided. The area around the workspace shall be sectioned off. Ensure that the conditions within the area have been made safe by control of flammable material.

d) Checking for presence of refrigerant

The area shall be checked with an appropriate refrigerating detector prior to and during work, to ensure the technician is aware of potentially flammable atmospheres. Ensure that the leak detection equipment being used is suitable for use with flammable refrigerants, i.e. non-sparking, adequately sealed or intrinsically safe.

e) Presence of fire extinguisher

If any hot work is to be conducted on the refrigeration equipment or any associated parts, appropriate fire extinguishing equipment shall be available to hand. Have a dry powder or CO₂ fire extinguisher adjacent to the charging area.

f) No ignition sources

No person carrying out work in relation to a refrigerating system which involves exposing any pipe work that contains or has contained flammable refrigerant shall use any sources of ignition in such a manner that it may lead to the risk of fire or explosion. All possible ignition sources, including cigarette smoking, should be kept sufficiently far away from the site of installation, repairing, removing and disposal, during which flammable refrigerant can possibly be released to the surrounding space. Prior to work taking place, the area around the

equipment is to be surveyed to make sure that there are no flammable hazards or ignition risks. No Smoking

signs shall be displayed.

g) Ventilated area

Ensure that the area is in the open or that it is adequately ventilated before breaking into the system or conducting any hot work. A degree of ventilation shall continue during the period that the work is carried out. The ventilation should safely disperse any released refrigerant and preferably expel it externally into the atmosphere.

h) Checks to the refrigerating equipment

Where electrical components are being changed, they shall be fit for the purpose and to the correct specification. At all times the manufacturer's maintenance and service guidelines shall be followed. If in doubt consult the manufacturer's technical department for assistance. The following checks shall be applied to installations using flammable refrigerants: The actual refrigerant charge is in accordance with the room size within which the refrigerant containing parts are installed; The ventilation machinery and outlets are operating adequately and are not obstructed; If an indirect refrigerating circuit is being used, the secondary circuit shall be checked for the presence of refrigerant; Marking to the equipment continues to be visible and legible. Markings and signs that are illegible shall be corrected; Refrigerating pipe or components are installed in a position where they are unlikely to be exposed to any substance which may corrode refrigerant containing components, unless the components are constructed of materials which are inherently resistant to being corroded or are suitably protected against being so corroded.

i) Checks to electrical devices

Repair and maintenance to electrical components shall include initial safety checks and component inspection procedures. If a fault exists that could compromise safety, then no electrical supply shall be connected to the circuit until it is satisfactorily dealt with. If the fault cannot be corrected immediately but it is necessary to continue operation, an adequate temporary solution shall be

used. This shall be reported to the owner of the equipment so all parties are advised. Initial safety checks shall include: That capacitors are discharged; this shall be done in a safe manner to avoid possibility of sparking; That there no live electrical components and wiring are exposed while charging, recovering or purging the system; That there is continuity of earth bonding.

7. Repairs to sealed components

- a) During repairs to sealed components, all electrical supplies shall be disconnected from the equipment being worked upon prior to any removal of sealed covers, etc. If it is absolutely necessary to have an electrical supply to equipment during servicing, then a permanently operating form of leak detection shall be located at the most critical point to warn of a potentially hazardous situation.
- b) Particular attention shall be paid to the following to ensure that by working on electrical components, the casing is not altered in such a way that the level of protection is affected. This shall include damage to cables, excessive number of connections, terminals not made to original specification, damage to seals, incorrect fitting of glands, etc. Ensure that apparatus is mounted securely. Ensure that seals or sealing materials have not degraded such that they no longer serve the purpose of preventing the ingress of flammable atmospheres. Replacement parts shall be in accordance with the manufacturer's specifications.

NOTE: The use of silicon sealant may inhibit the effectiveness of some types of leak detection equipment. Intrinsically safe components do not have to be isolated prior to working on them.

8. Repair to intrinsically safe components

Do not apply any permanent inductive or capacitance loads to the circuit without ensuring that this will not exceed the permissible voltage and current permitted for the equipment in use. Intrinsically safe components are the only types that can be worked on while live in the presence of a flammable atmosphere. The test apparatus shall be at the correct rating.

Replace components only with parts specified by the manufacturer. Other parts may result in the ignition of refrigerant in the atmosphere from a leak.

9. Cabling

Check that cabling will not be subject to wear, corrosion, excessive pressure, vibration, sharp edges or any other adverse environmental effects. The check shall also take into account the effects of aging or continual vibration from sources such as compressors or fans.

10. Detection of flammable refrigerants

Under no circumstances shall potential sources of ignition be used in the searching for or detection of refrigerant leaks. A halide torch (or any other detector using a naked flame) shall not be used.

The following leak detection methods are deemed acceptable for systems containing flammable refrigerants. Electronic leak detectors shall be used to detect flammable refrigerants, but the sensitivity may not be adequate, or may need re-calibration. (Detection equipment shall be calibrated in a refrigerant-free area). Ensure that the detector is not a potential source of ignition and is suitable for the refrigerant used. Leak detection equipment shall be set at a percentage of the LFL of the refrigerant and shall be calibrated to the refrigerant employed and the appropriate percentage of gas (25 % maximum) is confirmed. Leak detection fluids are suitable for use with most refrigerants but the use of detergents containing chlorine shall be avoided as the chlorine may react with the refrigerant and corrode the copper pipe-work. If a leak is suspected, all naked flames shall be removed/extinguished. If a leakage of refrigerant is found which requires brazing, all of the refrigerant shall be recovered from the system, or isolated (by means of shut off valves) in a part of the system remote from the leak. Removal of refrigerant shall be according to Removal and evacuation.

11. Removal and evacuation

When breaking into the refrigerant circuit to make repairs – or for any other purpose – conventional procedures shall be used. However, for flammable refrigerants it is important that best practice be followed, since flammability is a consideration. The following procedure shall be adhered to:

- a) safely remove refrigerant following local and national regulations;
- b) purge the circuit with inert gas;
- c) evacuate (optional for A2L);
- d) purge with inert gas (optional for A2L);
- e) open the circuit by cutting or brazing.

The refrigerant charge shall be recovered into the correct recovery cylinders if venting is not allowed by local and national codes. For appliances containing flammable refrigerants, the system shall be purged with oxygen-free nitrogen to render the appliance safe for flammable refrigerants. This process might need to be repeated several times. Compressed air or oxygen shall not be used for purging refrigerant systems. For appliances containing flammable refrigerants, refrigerants purging shall be achieved by breaking the vacuum in the system with oxygen-free nitrogen and continuing to fill until the working pressure is achieved, then venting to atmosphere, and finally pulling down to a vacuum (optional for A2L). This process shall be repeated until no refrigerant is within the system (optional for A2L). When the final oxygen-free nitrogen charge is used, the system shall be vented down to atmospheric pressure to enable work to take place. Ensure that the outlet for the vacuum pump is not close to any potential ignition sources and that ventilation is available.

12. Charging procedures

In addition to conventional charging procedures, the following requirements shall be followed. Ensure that contamination of different refrigerants does not occur when using charging equipment. Hoses or lines shall be as short as possible to minimise the amount of refrigerant contained in them. Cylinders shall be kept in an appropriate position according to the instructions. Ensure that the refrigeration system is earthed prior to charging the system with refrigerant. Label the system when charging is complete (if not already). Extreme care shall be taken not to overfill the refrigeration system. Prior to recharging the system it shall be pressure tested with OFN. The system shall be leak tested on completion of charging but prior to commissioning. A follow up leak test shall be carried out prior to leaving the site.

13. Decommissioning

Before carrying out this procedure, it is essential that the technician is completely familiar with the equipment and all its detail. It is recommended good practice that all refrigerants are recovered safely. Prior to the task being carried out, an oil and refrigerant sample shall be taken in case analysis is required prior to re-use of reclaimed refrigerant. It is essential that electrical power is available before the task is commenced.

- a) Become familiar with the equipment and its operation.
- b) Isolate system electrically.
- c) Before attempting the procedure ensure that: Mechanical handling equipment is available, if required, for handling refrigerant cylinders; All personal protective equipment is available and being used correctly; The recovery process is supervised at all times by a competent person; Recovery equipment and cylinders conform to the appropriate standards.
- d) Pump down refrigerant system, if possible.

- e) If a vacuum is not possible, make a manifold so that refrigerant can be removed from various parts of the system.
- f) Make sure that cylinder is situated on the scales before recovery takes place.
- g) Start the recovery machine and operate in accordance with instructions.
- h) Do not overfill cylinders. (No more than 80% volume liquid charge).
- i) Do not exceed the maximum working pressure of the cylinder, even temporarily.
- j) When the cylinders have been filled correctly and the process completed, make sure that the cylinders and the equipment are removed from site promptly and all isolation valves on the equipment are closed off.
- k) Recovered refrigerant shall not be charged into another refrigeration system unless it has been cleaned and checked.

14. Labelling

Equipment shall be labelled stating that it has been de-commissioned and emptied of refrigerant. The label shall be dated and signed. Ensure that there are labels on the equipment stating the equipment contains flammable refrigerant.

15. Recovery

When removing refrigerant from a system, either for servicing or decommissioning, it is recommended good practice that all refrigerants are removed safely. When transferring refrigerant into cylinders, ensure that only appropriate refrigerant recovery cylinders are employed. Ensure that the correct number of cylinders for holding the total system charge is available. All cylinders to be used are designated for the recovered refrigerant and labelled for that refrigerant (i.e. special cylinders for the recovery of refrigerant). Cylinders shall be complete with pressure relief valve and associated shut-off valves in good working order. Empty recovery cylinders are evacuated and, if possible, cooled before recovery occurs.

The recovery equipment shall be in good working order with a set of instructions concerning the equipment that is at hand and shall be suitable for the recovery of flammable refrigerants. In addition, a set of calibrated weighing scales shall be available and in good working order. Hoses shall be complete with leak-free disconnect couplings and in good condition. Before using the recovery machine, check that it is in satisfactory working order, has been properly maintained and that any associated electrical components are sealed to prevent ignition in the event of a refrigerant release. Consult manufacturer if in doubt. The recovered refrigerant shall be returned to the refrigerant supplier in the correct recovery cylinder, and the relevant Waste Transfer Note arranged.

Do not mix refrigerants in recovery units and especially not in cylinders.

If compressors or compressor oils are to be removed, ensure that they have been evacuated to an acceptable level to make certain that flammable refrigerant does not remain within the lubricant. The evacuation process shall be carried out prior to returning the compressor to the suppliers. Only electric heating to the compressor body shall be employed to accelerate this process. When oil is drained from a system, it shall be carried out safely.

Non-duct connected appliances containing A2L refrigerants with the supply and return air openings in the conditioned space may have the body of the appliance may be installed in open areas such as false ceilings not being used as return air plenums, as long as the conditioned air does not directly communicate with the air of the false ceiling.

Wiring Diagram

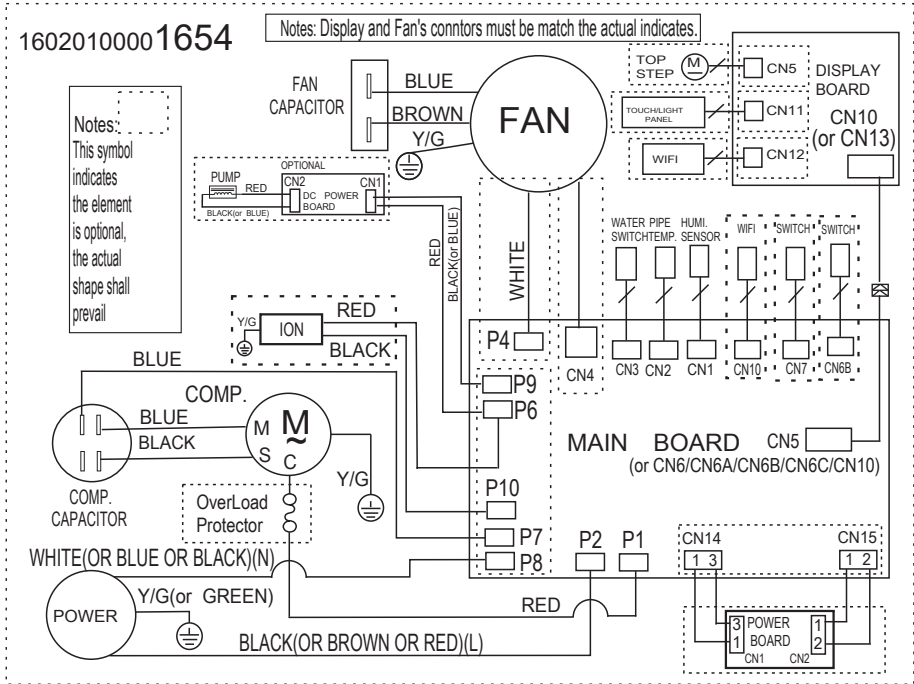

2. PRODUCT DESCRIPTION

2.1 General Overview

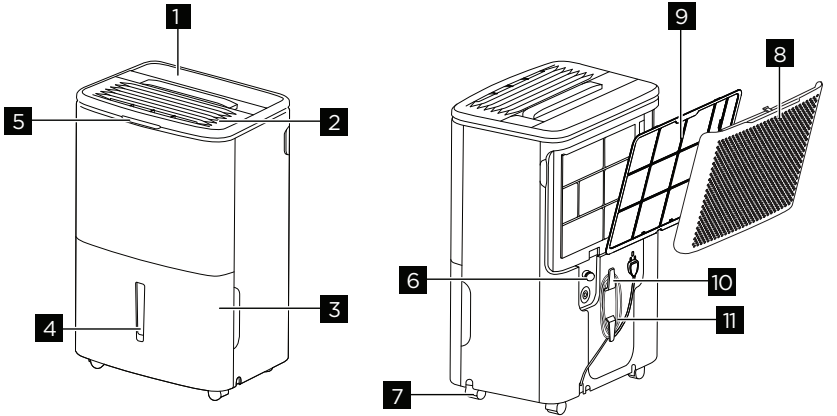

- 1** Control Panel
- 2** Louvre / Air outlet
- 3** Water Tank
- 4** Water Level Indication
- 5** Quick Glance Light
- 6** Drainage Plug / Water Outlet

- 7** Castors
- 8** Filter Lid / Air Intake
- 9** Dust Filter
- 10** Wire Tag
- 11** Power Cord

2.2 Quick Glance Light Behavior

Situation	Quick Glance Light Behavior
In Quiet or Continuous mode.	The light will turn off.
In Dry or Auto mode, when ambient humidity is at or higher the set humidity.	The light will turn off.
In Dry or Auto mode, when ambient humidity is lower then set humidity.	The light will continuously emit a blue light to show the set humidity has been reached.
When bucket full or clean filter light is on.	The light will emit orange light and gradually turn dark and bright every 4 sec.
When E4, EC, AS or ES error occur.	The light will emit red light and gradually turn dark and bright every 4 sec.
When unit is connecting to internet.	The light will flash white light.

Note: The light can be activated or deactivated by pressing and holding the “Fan Speed” button and “+” button simultaneously for 3 sec.

2.3 Control Panel Layout

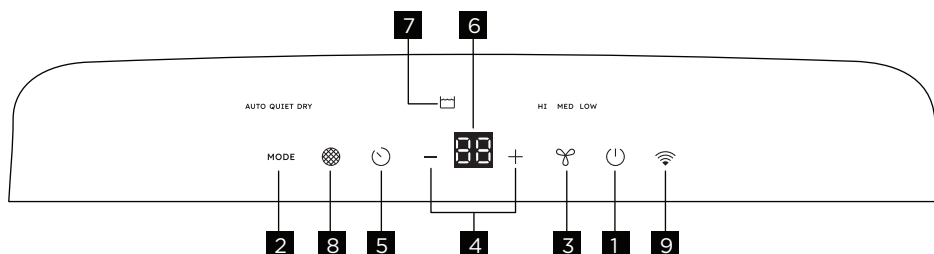

Number	Symbol	Buttons	Description
1		ON/OFF button	To power ON and OFF the appliance.
2	MODE	Mode button	To switch between the modes selection: <ul style="list-style-type: none"> • AUTO • QUIET • DRY
3		Fan speed button	To set the fan speed in Manual mode. You can switch between 3 speeds: <ul style="list-style-type: none"> • HI • MED • LOW
4	- / +	Minus / Plus button	To adjust the timer and humidity setting.
5		Timer button	To set the switch-on and switch-off time
Indicators			
6		Digital display	To show the humidity level, timer setting and error codes.
7		Water tank full	To remind you that the water tank is full and to empty the water tank. To remind you that the water tank has not been installed correctly
8		Filter change	To replace the high efficiency particle filter.
9		Wireless (selected models)	To show the status of the appliance's connectivity feature, whether it is active or inactive. Connectivity on selected models only.



See section "4. OPERATING INSTRUCTIONS" for the descriptions in detail.

3. BEFORE FIRST USE

3.1 Selecting a Location

IMPORTANT

1. Appliance must be upright for one hour prior to operating.
2. Place the appliance in a location with minimum 20cm distance around the unit (at least 40cm of air space on air outlet).
3. A dehumidifier operating in a basement will have little or no effect in drying an adjacent enclosed storage area, such as a closet, unless there is adequate circulation of air in and out of the area.
4. The dehumidifier must be installed on a level floor that will support it with a full bucket of water.
5. The presence of water in the water tank during first use is normal.

3.2 How It Works

1. The unit is designed to operate between 41°F (5°C), and 95°F (35°C) . The unit will not work properly if the temperature is out of this temperature range, or the performance of the unit decreases greatly.
2. The compressor circuit has an automatic 3-minute time delayed start if the unit is turned off and on quickly. This prevents overheating of the compressor and possible circuit breaker tripping.
3. If the appliance is unplugged or the electricity has been cut off when the unit is operating, the unit will set back to previous setting after the power is on again.

4. OPERATING INSTRUCTIONS

4.1 Usage of the Control Panel

Allow the unit to reach room temperature before operating.

To begin operating the dehumidifier, follow these steps:

NOTE: Unit must be upright for one hour prior to operating.

1. make sure the appliance is plugged in correctly.

NOTE: If the "☒" light is on, remove the water tank and re-install to reset the float switch.



2. Press "☒" to turn on the appliance. The appliance will run in the default setting of Auto mode. In this mode, the appliance will automatically set a comfortable humidity and fan speed according to the indoor environment.

NOTE: In this mode, set humidity and fan speed can not be changed manually and the display will show actual room humidity.



3. To use Quiet mode, press the Mode button to choose Quiet mode. The unit will run in low fan speed for the whole time and the unit will automatically set a comfortable humidity according to the indoor environment.

NOTE: In this mode, set humidity and fan speed can not be change manually and the display will show actual room humidity.



4. To use Dry mode, press the Mode button to choose Dry mode. In this mode, you can press the “-” or “+” buttons to choose a humidity value between 35% to 85%, so the room is kept at a comfortable humidity. Pressing the - or + buttons will change the humidity selection in 5% increments. 5 seconds after you have set the desired humidity, the readout will display the actual room humidity.

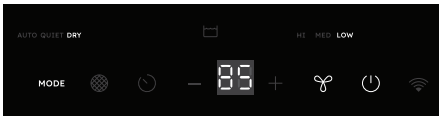

5. During the Dry mode, You can also use the FAN SPEED button to change the fan speed to Hi, Med or Lo. The indicator light will show the setting you have selected. A higher fan speed will result in quicker moisture removal.



6. To use CONTINUOUS mode, when in Dry mode pressing the “-” button until the display reads CO. In this mode, the unit will continuously on and the unit will only display CO not the room humidity. To leave this mode, press the “+” button.



7. The TIMER function enables you to either Delay Start or Delay Stop the unit in the choice from 0.5 hour to 24 hours. If the unit is running, then selecting Timer will turn the unit off in the hours that will be set (Delay Stop). If the unit is off, then selecting Timer will turn the unit on in the hours that will be set (Delay Start). TIMER setting: First press TIMER button, then adjust timer setting, by tapping or holding the “-” or “+” button to change the delay timer at 0.5 hour increments, up to 10 hours, then by 1 hour increments up to 24 hours. The control will count down the time remaining (8h, 7.5h, 7h etc.) until the unit either starts or stops. For the Delay Start, the fan speed and humidity maintained will be the same as previous setting. After TIMER setting finishes, pressing TIMER button again at any time will stop the TIMER function. The Delay Start/Stop Feature will work until the unit either starts or stops. Once that happens the above steps have to be repeated.

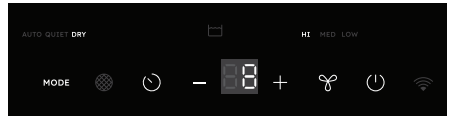

NOTE:

- Before entering TIMER setting, make sure power is being supplied to the unit.
- Before entering TIMER setting, select a desired setting for operation when the unit turn on.

8. The Filter reset light will illuminate after 250 hours of operation. At this time refer to the care and cleaning section to remove and clean the filter. Once the filter has been cleaned and replaced, simply press the Filter reset button to extinguish the light.



9. Press and hold the “-” and “+” for 3 sec can activate or deactivate the LOCK function. The display will show LC for 5

secs. The control panel will be lock and the setting can not be changed.



10. The appliance is equipped with a Wi-Fi chip that enables it to be connected to the internet and via the App enables you to control and access its full functionality remotely. Download our App and follow the instructions for how to connect your appliance to the internet. When the connection is established, the "Wi-Fi" indicator will light up. (selected units only)



11. The unit is equipped with a device called an ionizer. This device can only be activated and deactivated via the App, which can be downloaded onto your smart phone device. When the ionizer is activated, it will help to reduce airborne pollutants and clean your room's air faster.

12. Press "⏻" to turn off the appliance.

NOTE: After a power outage, the unit will memorize the last setting and return the unit to the same setting once power is restored.



4.2 Fault Codes

1. If the display reads "AS" or "ES", a sensor has failed. Contact your Authorized Electrolux Service Center.

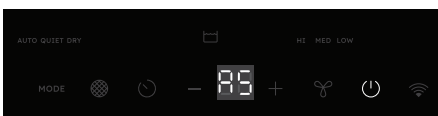

2. If the display reads "EC", check the following operating conditions. Outlet voltage should be $110V \pm 10\%$ and the surrounding temperature should be within the range of 41 °F to 89 °F. Unplug the unit and plug it in again under normal operating conditions. If the "EC" code persists, contact your Authorized Electrolux Service Center.

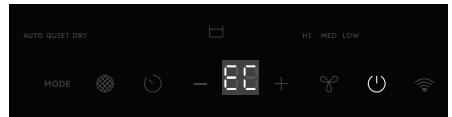

3. If the display reads "E4", the communication between display PCB and main control PCB is faulty. Contact your Authorized Electrolux Service Center.



4.3 Removing Collected Water

1. Emptying the water tank:

- a. When the water tank is full, the unit will shut down and the "⏻" indicator will illuminate.



- b. Do not move the unit at this time otherwise water may spill on the floor.
c. Press sides of bucket gently to unclip the bucket from the unit.
d. Remove the bucket as shown in the photographs below and empty the bucket.

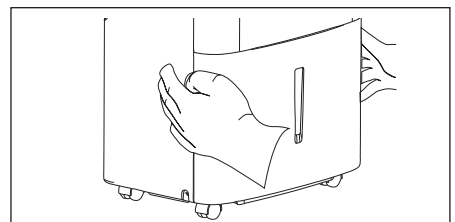

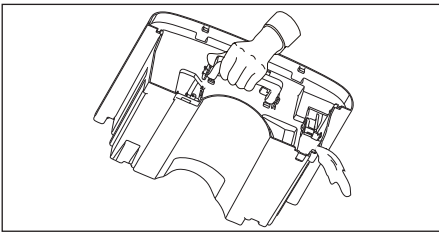
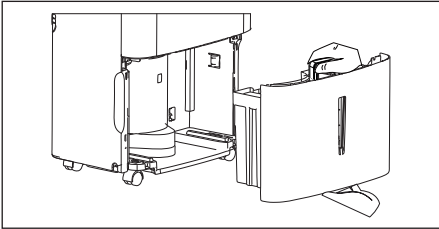
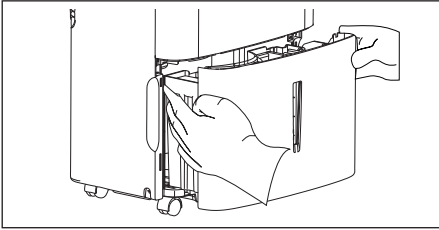

! WARNING

Discard water from bucket. Water is not potable and cannot be used for drinking.

- e. Replace the empty bucket back into the unit and once seated correctly, the unit will start up again.
- f. You should hear a click when the bucket is in the correct position.

If the bucket full light does not extinguish, check that the float is correctly snapped in place.

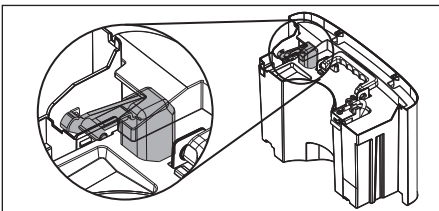

2. Continuous Drainage:

- a. For continuous drainage operation, you will need a drainage hose, drainage adaptor(sold separately) and a drain nearby to discharge the water into.

Note: Drainage hose and adaptor are not coming with dehumidifier, more information please contact Electrolux service center.

- b. Unscrew the drainage cap on the back side of the unit. (fig.1)

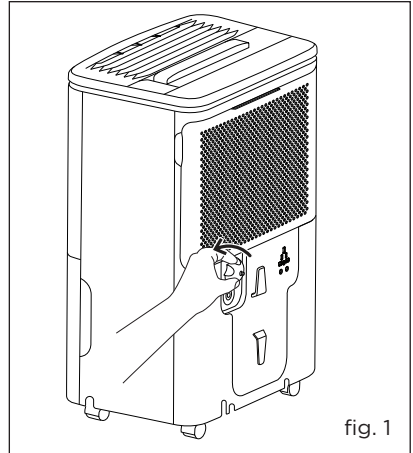

- c. Connect the drainage adaptor to the drain outlet. And Screw the adaptor.(fig.2)

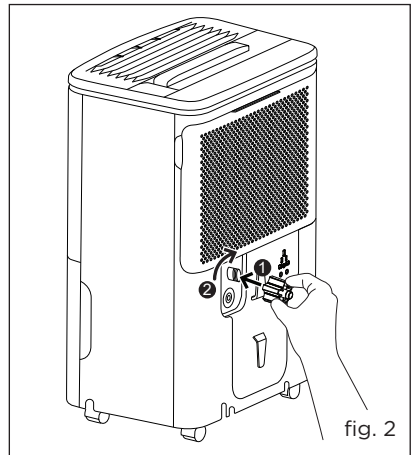

- e. Connect one end of the drainage hose to the drainage adaptor. Make sure the hose is secure so there are no leaks. (fig.3)

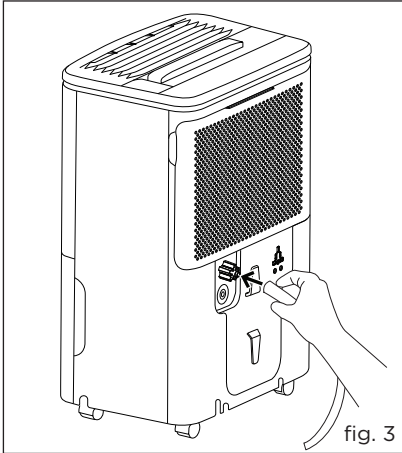

fig. 3

- g. Lead the other end of drainage hose into a drain that is lower than the unit. (fig.4)

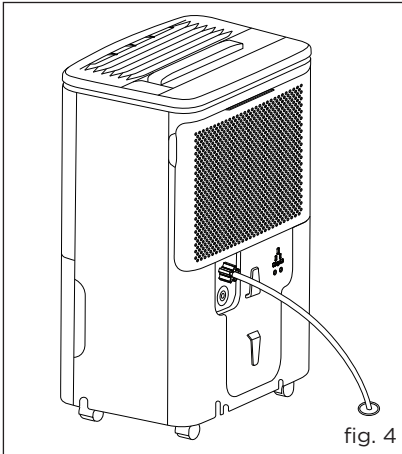

fig. 4

- h. Select the desired humidity setting and fan speed on the unit for continuous draining to start.

NOTE:

- Check the seal between the hose and the drainage adaptor. If there is a small leak then replace the hose gasket and re-tighten the hose.
- It is recommended that a Dehumidifier Drainage Hose - inner diameter 13.5mm(outer diameter 16.5mm). Make sure there are no kinks or elevations in the hose.
- Please ensure drainage adaptor is screwed securely to the drain outlet to prevent leakages.

5. CARE AND CLEANING

5.1 Filter

Clean the filter every two weeks based on normal operating conditions.

To remove the filter:

- a. Open the back grille.

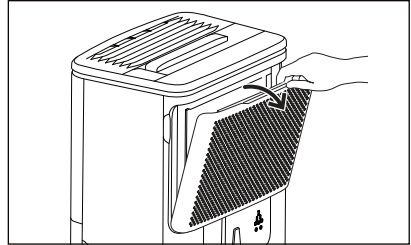

- b. Detach the filter from the back of the grille by pressing the tabs as shown below.

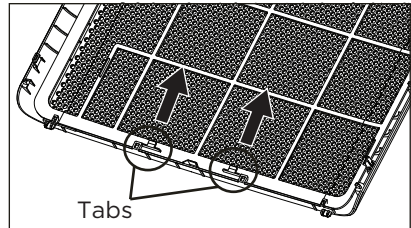

- c. Wash the filter with clean water then dry.
d. Re-install the filter.

5.2 Cabinet

- a. Dust cabinet with an oil-free cloth, or using a damp cloth.
b. Vacuum grill using brush attachment.
3. Water Bucket

Clean the Water Bucket every two weeks based on normal operating conditions.

- a. Clean bucket with warm water and detergent.

NOTE: This unit has available space for use of additional filters. There are different types of additional filters, which are sold separately. You can purchase additional air filters by visiting electrolux.com

5.3 Storage

- a. Unplug the appliance, then tidy up the power cord using the tag at the back of the unit.

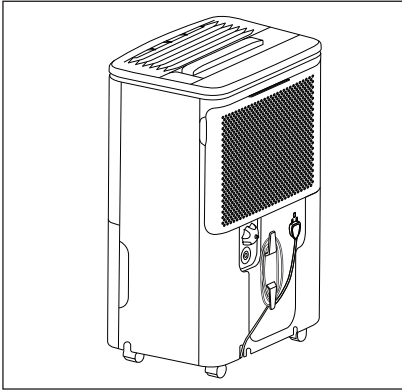

- b. Empty the water tank and clean the
- c. Dry the appliance and all accessories by airing.
- d. Pack it with plastic bag or return it to its carton then place the unit in a cool and dry place.

5.4 Normal Sounds

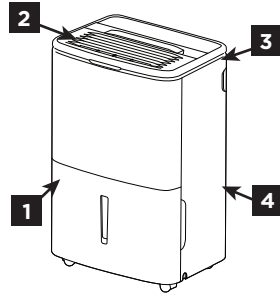

- 1 Dripping Sound**
The sound of dripping water may be heard during the dehumidification cycle.
- 2 Sound of Rushing Air**
At the top of the unit, you may hear the sound of rushing air being moved by the fan.
- 3 Gurgle/Hiss**
“Gurgling or hissing” noise may be heard due to refrigerant passing through evaporator during normal operation.
- 4 High Pitched Chatter**
Today’s high efficiency compressors may have a high pitched chatter during the dehumidification cycle.

6. WHAT TO DO IF ...

Before calling for service, review this list. It may save you time and expense. This list includes common occurrences that are not the result of defective workmanship or materials in this appliance.

OCCURRENCE	SOLUTION
Dehumidifier does not operate.	<ul style="list-style-type: none"> • Wall plug disconnected. Push plug firmly into wall outlet. • House fuse blown or circuit breaker tripped. Replace fuse with time delay type or reset circuit breaker. • The dryness level you selected has been reached. Dehumidifier automatically shuts off when selected amount of moisture has been removed from the air. If you want to remove more moisture, Select ‘CONTINUOUS’ by using the humidity button or knob. After the dehumidifier starts, reset the control to the desired setting. • Bucket not installed properly. See “Removing Collected Water”. • Water in the bucket has reached its preset level. Dehumidifier automatically turns off when this occurs. Empty bucket and return bucket to position. • Dehumidifier is not turned on. Turn unit on. • “” light is on. Remove bucket, empty water and re-install correctly.

Dehumidifier runs too much.	<ul style="list-style-type: none"> • Windows or doors near dehumidifier are open to outdoors. Close all windows or doors to outside. • Area to be dehumidified is too large. Check with your dealer to see if capacity is adequate. • Air movement through dehumidifier is blocked. Grill may be dirty. Use brush attachment of vacuum cleaner to clean grill. See “Care and Cleaning”. Dehumidifier must be placed in a space that does not restrict air flowing into the rear coil or out of the front grill. • Dehumidifier has been installed or restarted recently. The higher the moisture in the room, the longer the dehumidifier will operate. • Dehumidifier is in the CONTINUOUS mode and will remain on in this mode, use the humidity button or knob to set a RH% higher level.
Dehumidifier is operating but room is not dry enough.	<ul style="list-style-type: none"> • Humidity setting is too high. Press the HUMIDITY button or rotate knob to a lower setting or choose CONTINUOUS for maximum dryness. • Dehumidifier has been installed or restarted recently. The higher the moisture in the room air, the longer it takes for the room air to become dry. • Dehumidifier does not have sufficient clearance to operate. Air flow to the air outlet is blocked. See “Selecting a Location”. • Room temperature is too low. Unit will not operate satisfactorily if the room temperature is below 41°F(5°C). See “Operating Conditions”. • Refer to causes under DEHUMIDIFIER RUNS TOO MUCH.
Frost appears on coils behind the filter	<ul style="list-style-type: none"> • Dehumidifier has been turned on recently. This is normal due to refrigerant rushing through the coil. Frost will usually disappear within 60 minutes. • Room Temperature is too low. All models will operate satisfactorily at temperatures greater than 41°F (5°C).
Fan noise.	<ul style="list-style-type: none"> • Air is moving through the dehumidifier. This is a normal sound.
Trouble connecting the Smart appliance to your wireless network or experiencing an Issue with the app.	<ul style="list-style-type: none"> • Please visit Electrolux.com and select the Contact & Support section to view Frequently Asked Questions.

7. ENVIRONMENT CONCERNS

Recycle the materials with the symbol . Put the packaging in applicable containers to recycle it. Help protect the environment and human health and to recycle waste of electrical and electronic appliances.

Do not dispose appliances marked with the symbol  with the household waste. Return the product to your local recycling facility or contact your municipal office.

目錄

1. 安全資訊	21
2. 產品描述	28
3. 首次使用之前.....	30
4. 操作指示.....	30
5. 維護保養、清潔及存放.....	34
6. 疑難排解.....	35
7. 環境注意事項	36

我們總是為您著想

感謝您購買伊萊克斯電器。您選擇了一款結合多年專業經驗與創新的產品。它精巧時尚，且處處為您的使用情境精心設計。不論您何時使用，都能獲得絕佳的體驗。歡迎您加入伊萊克斯產品使用者的行列。

請瀏覽我們的網站，藉以：



取得使用建議、疑難排解方法及維修服務資訊：
(台灣) www.electrolux.com.tw



註冊您的產品，享受更優質的服務：
(台灣) <https://www.electrolux.com.tw/electrolux-member/#/>



為您的產品購買配件、耗材及原廠零件：
(台灣) **0800-888-259**

客戶關懷和服務

請務必使用原廠的零件。

聯絡我們的客服專線時，請確保提供以下資料：型號、PNC 號碼和序號。這些資訊可在機身標籤上找到。

使用手冊中的符號：

 警告/注意——安全資訊。

 一般資訊及使用訣竅。

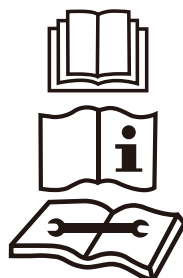

 環境資訊。

內容可能會有變動，恕不另行通知。



使用可燃性冷媒，
若洩漏有火災風險

1. 安全資訊

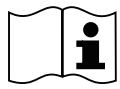
符號	註	說明
	警告	此符號表示此裝置使用可燃性冷媒。如果冷媒洩漏或暴露於外部點火源，則有火災風險。
	注意	此符號表示應仔細閱讀使用手冊。
	注意	此符號表示服務人員應參考安裝手冊處理此設備。
	注意	此符號表示提供使用手冊或安裝手冊等資訊。

安裝及使用本產品前，請仔細閱讀使用手冊。假如因安裝或使用不當而導致任何傷害或損壞，製造商恕不負責。您必須將使用手冊存放在安全而方便取得的地方，以供日後參考。

警告

為了您的安全

- 請勿於此產品或其他電器周邊存放瓦斯或其他可燃性氣體或液體。詳讀產品標示上的可燃性和其他警告標示。
- 水箱內的水不可飲用，請直接倒掉。

電力資訊

- 為您的安全和保障，這款除濕機裝置電線為三插頭。請勿於任何情況下，剪斷或移除插頭上的接地圖插。
- 您的除濕機必須直接插進適當接地和極化的三插座。若插座不接受三插頭，或者您不確定插座是否確實接地或有無保險絲或斷電的延遲保護，請要求電工依照國家電力法規安裝適用於當地法規的插座。

- 關閉除濕機時不可直接拉扯電線。穩抓插頭，直接從插座拉出。
- 請勿捏、彎折電線或將其打結。

孩童安全防範

- 拆開除濕機的包裝後請立刻丟棄紙箱、塑膠袋和填充物。孩童不應將這些物品當作玩具。
- 電器運轉處不可放任孩童自行遊玩。不要讓他們坐或站在電器上。
- 這款電器不適用於身心感官障礙人士（包括孩童）或經驗或知識不足人士，除非有負責其安全的人士監管或給予使用指示。
- 孩童應該受到監管以確保不把玩電器。

危險

避免重傷或死亡

- 此款除濕機沒有可供使用者自行更換的零件。維修請聯繫認證的伊萊克斯服務專員。
- 請勿將手指或物品插入或放入出風口或除濕機背面進氣口格柵。
- 請勿以拉扯電線或關掉電箱的方式啟動或停止除濕機。
- 請勿剪斷或毀損電線。請勿拉扯電線。
- 若電線有毀損，需要透過認證的伊萊克斯服務專員更換。
- 故障發生時，(火花、燒焦味等等) 立刻停止運轉，拔除電線，並致電認證的伊萊克斯服務專員。
- 請勿以潮濕的手操作除濕機。請勿飲用除濕機裡的水。
- 若提供的電線有損壞，必須由廠商、服務專員或類似合格人員更換以避免危險。
- 應該遵照國家線路規定安裝電器。

注意

避免傷害或損毀設備和其他配件

- 請勿將出風口直接對準火爐或其他火源處，可能導致火爆。
- 請勿攀爬本機或放置東西在本機上。請勿吊掛東西在本機上面。
- 請勿放置裝有液體的容器在本機上。
- 長時間不使用除濕機的話，請關閉電源。
- 使用本機時請務必裝上前置濾網。
- 請勿阻擋或覆蓋本機進氣口格柵和出風口區域。
- 確保任何電力/電子設備距離本機至少一公尺遠。
- 請勿於本機附近使用或存放任何可燃性瓦斯或類似物質。

警告

避免火災或觸電。請勿使用延長線或轉接插頭。請勿移除電源線插頭的任何插腳。

接地型牆壁插座

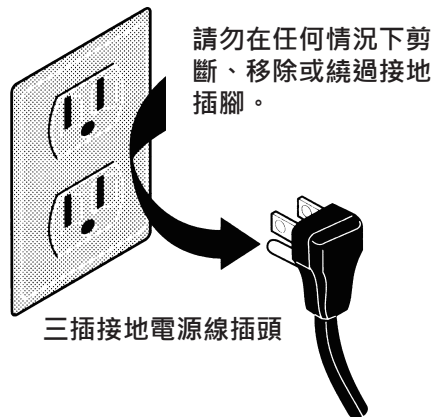

請注意：檢查電器機身標籤上的冷媒類型



警告

可燃性冷媒

- 應遵照設備廠商建議來處理。需要其他技術人員的專業維修應由合格的可燃性冷媒技術人員在旁監管。
- 請勿調整電線長度或使用延長線為本機供電。
- 請勿和其他電器產品共用單一插座。不適當的供電可能造成火災或觸電。
- 請仔細遵照指示處理、安裝、清除、維護本機以避免任何損傷或危險。
- 本機內使用的是可燃性冷媒R32。維修或丟棄本機時，應適當地回收冷媒(R32)，不可直接釋放至空氣中。
- 須檢視以合乎國家氣體規定。
- 保持通風口不受阻擋。
- 應適當放置電器以預防機械損傷。
- 警語應明訂電器應存放於通風良好的適用空間大小區域。
- 任何處理或接觸冷媒迴路的人員，必須持有業界公認的評估機構頒發的現行有效證書，授權他們按照業界認可的評估規範安全地處理冷媒事宜。

這類型的作業程序範例為：

- 拆卸機身部件以便處理冷媒迴路
- 拆開密封的組件
- 拆開通風封口

- 本機附近不應有任何開放式火源或可能產生火花/電弧的開關或類似裝置，以避免造成可燃性冷媒點燃。請仔細遵照指示放置或維護本機以預防機械損傷。
- 請勿使用除了廠商建議的方法之外的方式加速除霜程序或清潔。
- 電器應放置於沒有持續運轉的點火源(例如：明火、運轉中的瓦斯電器)空間和接近電器的點火源(例如：運轉中的電暖爐)。
- 請勿刺穿或用火燒。
- 注意冷媒可能無氣味。

1. 運送含可燃性冷媒的設備

見運送法規。

2. 使用符號標示設備

見當地法規。

3. 棄置含可燃性冷媒的設備

見國家法規。

4. 存放設備/電器

設備存放應遵照廠商指示。

5. 存放含包裝(未售出)的設備

應備有防護包裝不讓包裝內的設備機械損傷而造成冷媒外洩。可一起存放的最大設備數量視當地法規而定。

6. 維修服務資訊

a) 檢查周遭區域

開始處理含有可燃性冷媒的系統前，必須進行安全檢查以將點燃的風險最小化。關於製冷系統維修，對系統進行作業前應遵守下述注意事項。

b) 作業程序

應根據受控程序進行作業，以將進行作業時存在可燃性氣體或蒸氣的風險最小化。

c) 一般作業區域

所有維護人員及當地的其他作業人員都應知曉進行的作業性質。應避免密閉空間作業。應分隔工作空間周圍的區域。控制可燃性物質以確保區域內的作業條件安全。

d) 檢查冷媒是否存在

作業前和作業期間應使用適當的冷媒偵測器檢查區域，以確保技術人員瞭解潛在可燃性環境。確保使用的洩漏偵測設備適用於可燃性冷媒，即無火花、充分密封或本質安全。

e) 準備滅火器

若對製冷設備或任何相關零件進行任何高溫作業，應準備適當的滅火設備。將乾粉或 CO₂ 滅火器放在充填區域附近。

f) 無點火源

進行製冷系統相關作業而接觸任何含有或曾含有可燃性冷媒管道的人員，不得以可能導致火災或爆炸風險的方式使用任何點火源。在安裝、維修、拆卸和處置過程中可燃性冷媒可能釋放至周圍空間，故應與所有可能的點火源（包括吸菸）保持足夠的距離。進行作業前應檢查設備周圍區域，以確保沒有易燃危害或點燃風險。應設置「禁止吸菸」標誌。

g) 使作業區域保持通風

接觸系統或進行任何高溫作業前，請確保區域在開放空間或通風良好。作業期間應保持一定程度的通風。通風應讓任何釋放的冷媒安全地消散，最好向外排放到空氣中。

h) 檢查製冷設備

若要更換電氣元件，則元件應適合用途並符合正確規格。應隨時遵守製造商的維護和維修準則。如有疑問，請向製造商的技術部門尋求協助。應對使用可燃性冷媒的裝置進行下述檢查：充填量符合安裝含冷媒零件的空間大小；通風設備和通風口正常運作且暢通；如果使用間接製冷迴路，則應檢查次要迴路是否存在冷媒；設備標示仍然清晰可見。應修正難以辨認的標示和標誌；製冷管或零件安裝在不太可能暴露於任何可能腐蝕含冷媒元件物質的位置，除非元件是以本質耐腐蝕或受到適當保護以防腐蝕的材料所製成。

i) 檢查電器裝置

電氣元件維修和維護應包括初始安全檢查和元件檢查程序。如果存在可能危及安全的故障，則在得到妥善處理前不得將電源連接至電路。如果無法立即修正故障但必須繼續運作，應採用適當的臨時解決方法。應向設備所有者報告以便通知各方。

初始安全檢查應包括：電容器已放電；應以安全的方式進行，避免產生火花的可能性；對系統進行充填、回收或迫淨時，沒有暴露的帶電電氣元件和接線；有接地連續性。

7. 維修密封元件

- a) 維修密封元件期間，應在拆卸密封護蓋等之前切斷要處理設備的所有電源。如果維修期間絕對必須為設備供電，則應在最關鍵的位置設置永久運作形式的洩漏偵測，以警告潛在危險情況。
- b) 應特別注意下述事項，確保處理電氣元件時不會改變外殼而影響保護程度。這包括纜線損壞、連接數量過多、端子不符合原始規格、密封件損壞、固定頭安裝不正確等。確保裝置安裝牢固。確保密封件或密封材料未劣化，導致無法再發揮防止可燃性氣體進入的作用。替換零件應符合製造商規格。

註：使用矽密封膠可能會抑制某些類型洩漏偵測設備的有效性。處理本質安全元件之前不必加以隔離。

8. 維修本質安全元件

請勿對電路施加任何永久電感或電容負載，除非確保這不會超過所用設備允許的電壓和電流。本質安全元件是唯一可在有可燃性氣體的情況下活電作業的類型。測試裝置的額定值應正確。僅使用製造商指定的零件來更換元件。其他零件可能導致冷媒因洩漏而在空氣中點燃。

9. 佈線

檢查佈線是否會受到磨損、腐蝕、過高壓力、震動、銳利邊緣或任何其他不利的環境影響。檢查也應將來自壓縮機或風扇等來源的老化或持續震動的影響納入考量。

10. 偵測可燃性冷媒

在任何情況下，均不得在搜尋或偵測冷媒洩漏時使用潛在點火源。不得使用鹵素燈（或任何其他使用明火的偵測器）。

就含有可燃性冷媒的系統而言，以下洩漏偵測方法被視為可接受。應使用電子洩漏偵測器偵測可燃性冷媒，但靈敏度可能不足，或可能需要重新校正。（應在無冷媒的區域校正偵測設備。）確保偵測器並非潛在點火源且適合使用的冷媒。應將洩漏偵測設備設定在冷媒的易燃下限百分比並依照採用的冷媒進行校正，且確認適當的氣體百分比（最大 25%）。洩漏偵測液適用於大多數冷媒，但應避免使用含氟清潔劑，因為氟可能會與冷媒產生反應並腐蝕銅管。如果懷疑洩漏，則應移除 / 熄滅所有明火。如果發現冷媒洩漏而需要銅焊，應從系統回收所有冷媒，或隔離（透過關斷閥）在遠離洩漏處的系統部分。應遵照移除和排空法規移除冷媒。

11. 移除和排空

為了進行維修或任何其他目的而接觸冷媒迴路時，應採用慣例程序。但遵循最佳實務很重要，因為可燃性是一大考量。應遵守以下程序：

- a) 安全地依照當地和國家法規移除冷媒
- b) 惰性氣體迫淨迴路
- c) 排空(A2L選項)
- d) 用惰性氣體迫淨 (A2L選項)
- e) 透過切割或銅焊開啟迴路。若當地和國家規定不允許排放，應將冷媒回收至正確的回收鋼瓶。含有可燃性冷媒的電器，應使用無氧氮氣(OFN)「沖洗」系統以確保裝置安全。可能要多次重複此過程。不得將壓縮空氣或氧氣用於此任務。針對含可燃性冷媒的電器，沖洗方式應是使用OFN破壞系統中的真空並繼續充填直到達到工作壓力，然後排放至空氣中，最後抽真空(A2L選項)。應重複此過程，直到系統內沒有冷媒為止。
使用最終OFN充填時，應將系統排放至大氣壓力以便進行作業。確保真空泵浦的出口未靠近任何點火源且通風良好。

12. 充填程序

除了慣例的充填程序之外，應遵守下列方式：確保使用充填設備時未出現不同冷媒的汙染。管線應盡量縮短以減少內含冷媒。

鋼瓶應依照指示放置。為系統充填冷媒之前，確保製冷系統接地。充填完成後標示系統(若尚未進行)。應特別小心不要過度充填製冷系統。充填系統前應使用OFN進行壓力測試。應在充填完成後但未啟用前對系統進行洩漏測試。離開現場前應進行追蹤洩漏測試。

13. 停用

執行此程序前技術人員必須完全熟悉設備及其所有細節。建議的良好做法是安全回收所有冷媒。執行任務前應取得油和冷媒樣本，以防在重複使用回收的冷媒前需要分析。開始任務前必須有電力可用。

- a) 熟悉設備及其操作。
- b) 對系統進行電氣隔離。
- c) 執行程序前請確保：可視需要使用機械搬運設備搬運冷媒鋼瓶；準備並正確使用所有個人防護裝備；回收過程全程由合格人員監督；回收設備和鋼瓶符合相關標準。
- d) 如果可能，請抽空冷媒系統。

- e) 如果無法建立真空，則製作歧管，以便從系統各部分移除冷媒。
- f) 進行回收前確保鋼瓶位於計重秤上。
- g) 啟動回收機器並依照製造商的指示操作。
- h) 請勿過度充填鋼瓶。(不超過 80% 容積液體充填量)。
- i) 請勿超過鋼瓶的最大工作壓力，即使暫時超過也一樣。
- j) 正確充填鋼瓶並完成程序後，立即從現場移走鋼瓶和設備並關閉設備上的所有隔離閥。
- k) 不得將回收的冷媒充填至另一個製冷系統，除非經過清潔和檢查。

14. 標示

設備應貼上標籤，說明已停用並排空冷媒。應在標籤上註明日期並簽名。確保設備上有說明設備含有可燃性冷媒的標籤。

15. 回收

為了維修或停用而從系統移除冷媒時，建議的良好做法是安全移除所有冷媒。將冷媒轉移至鋼瓶時，確保僅採用合適的冷媒回收鋼瓶。確保鋼瓶數量正確以容納系統總充填量。所有要使用的鋼瓶都被指定用於回收的冷媒，並針對該冷媒貼上標籤（即用於回收冷媒的特殊鋼瓶）。鋼瓶應整齊配備處於良好狀態的洩壓閥及相關的關斷閥。空的回收鋼瓶已排空並在進行回收之前冷卻（如果可能的話）。

回收設備應處於良好狀態並附有關於設備的說明，且應適用於回收可燃性冷媒。此外，應準備經過校正並處於良好狀態的計重秤。

軟管應配無洩漏分離接頭並處於良好狀態。使用回收機器前請確定機器處於正常運作狀態、得到妥善維護，且所有相關電氣元件已密封以防在冷媒釋放時燃起。如有疑問，請諮詢製造商。應使用正確的回收鋼瓶將回收的冷媒送回給冷媒供應商，並安排相關的廢棄物轉運單。請勿在回收裝置中混合冷媒，尤其是鋼瓶內。

若要移除壓縮機或壓縮機油，請確保已排空至可接受的程度，確定可燃性冷媒不會殘留在潤滑劑中。應在將壓縮機送回給供應商前進行排空程序。只能採用對壓縮機本體進行電加熱來加快此過程。從系統排油時，應以安全的方式進行。

含有A2L冷媒的無管電器在適宜位置有送風口和回風口的電器主體可以安裝於開放區域，像是不能作為回風區的偽天花板的偽天花板，前提是空調不直接對應偽天花板的空氣。

有取得審驗證明之低功率射頻器材，非經核准，公司、商號或使用者均不得擅自變更頻率、加大功率或變更原設計之特性及功能。

低功率射頻器材之使用不得影響飛航安全及干擾合法通信；經發現有干擾現象時，應立即停用，並改善至無干擾時方得繼續使用。前述合法通信，指依電信管理法規定作業之無線電通信。

低功率射頻器材須忍受合法通信或工業、科學及醫療用電波輻射性電機設備之干擾。

有鑒於世界各國對綠色環保意識的重視，伊萊克斯依循RoHS「危害性限制物質指令」誠實標示產品化學物質含量，關於本產品的RoHS聲明書，請上伊萊克斯官網 →「維修與服務」→「通過歐盟RoHS 認證-了解更多」，依產品類別及型號檢索。
<http://www.electrolux.com.tw/support/rohs/>

2. 產品描述

2.1 各部位概覽

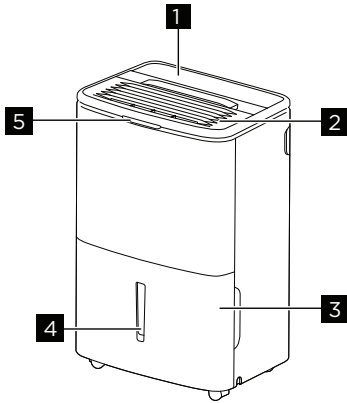

- 1 控制面板
- 2 出風口
- 3 水箱
- 4 水位指示窗
- 5 狀態指示燈
- 6 排水孔蓋/出水口

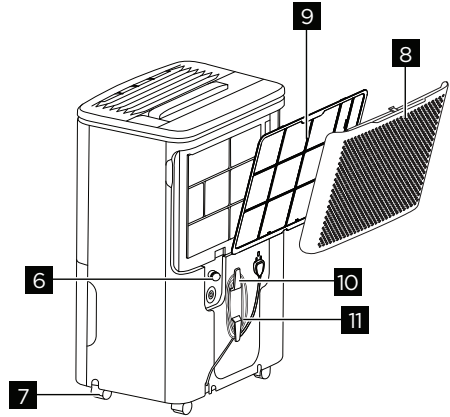

- 7 滾輪
- 8 濾網蓋/進氣口
- 9 前置濾網
- 10 電源線收納勾
- 11 電源線

2.2 狀態指示燈號

情況	狀態指示燈號
使用睡眠模式或連續除濕模式	燈號熄滅
使用乾衣模式或智慧模式時，當環境濕度等同或是高於設定濕度	燈號熄滅
使用乾衣模式或智慧模式時，當環境濕度低於設定濕度	持續亮藍燈代表已達設定濕度
當水箱滿水或濾網清潔指示燈亮起	持續亮橘燈並且每4秒會轉暗又轉亮
當出現E4, EC, AS 或 ES 錯誤	持續亮紅燈並且每4秒會轉暗又轉亮
當除濕機準備進行連線設定時	閃爍白燈

註：同時長按「風速」鍵和「+」鍵3秒鐘可啟動或熄滅燈號。

2.3 控制面板

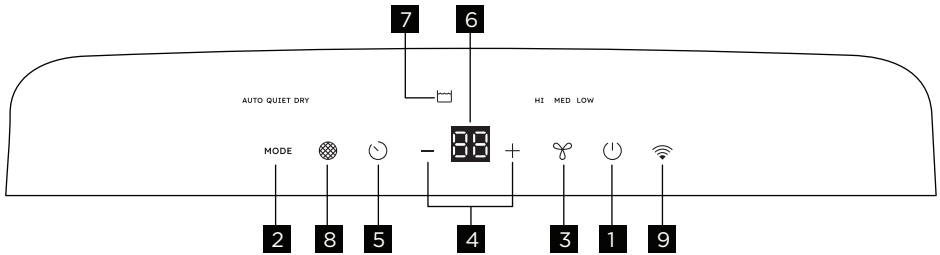

編號	符號	按鍵	描述
1		電源鍵	啟動和關閉本產品
2	MODE	模式鍵	在各種模式之間切換： <ul style="list-style-type: none"> 「AUTO」(智慧) 「QUIET」(睡眠) 「DRY」(乾衣)
3		風速鍵	手動設定風速，有3種風速可供選擇： <ul style="list-style-type: none"> 「HI」(高) 「MED」(中) 「LOW」(低)
4	- / +	減號/加號鍵	調整定時和濕度設定
5		定時鍵	設定自動定時開機及定時關機時間
指示燈			
6		數值顯示器	顯示濕度、定時和錯誤代碼
7		滿水	提醒您水箱已滿，請將水箱中的水倒掉 提醒您水箱並未正確安裝
8		濾網清潔指示燈	提醒您需清潔前置濾網
9		Wi-Fi指示燈	顯示本機的連線狀態

3. 首次使用之前

3.1 選擇使用位置

重要資訊

1. 本產品在運作之前，必須直立放置一個小時。
2. 放置本產品的位置，應和四周其他物件保持最少20公分的距離(出風口位置至少應保留40公分距離)。
3. 假如除濕機在狹小的空間中運作，為鄰近的密閉區域(例如衣櫃等)除濕，除非有適當的通風，讓空氣進出相關區域，否則除濕效果將會減小或沒有效果。
4. 除濕機必須在水平的地面上使用，讓除濕機即使水箱滿水，也不會因為地表傾斜而滑動。
5. 首次使用本產品時，水箱內可能會有出廠功能測試時所殘留的水份，這屬於正常現象。

3.2 如何運作

1. 本產品設計在 5°C 到 35°C 的環境下運作。如果溫度在上述範圍之外，本產品將無法正常運作，或效能將大幅下降。
2. 若快速關閉再啟動本產品，壓縮機電路會自動啟動3分鐘延遲啟動功能。此設定可防止壓縮機過熱和跳電。
3. 若在本產品運作期間拔除電源，或電力中斷，重新啟動後會回到電力中斷前的設定。

4. 操作指示

4.1 使用控制面板

請按照以下步驟開始使用除濕機

註：產品開始運作前，必須先直立放置一小時。

1. 確保產品電源插頭已正確插入插座。

註：如果 "☒" 滿水燈號亮起，請拉出水箱後重新裝入以重置設定。

2. 按下 "☺" 啟動本電器。本產品會以智慧模式的預設值運轉。此模式中，產品會根據室內環境自動設定在舒適濕度和風速。

註：在此模式中，無法手動設定濕度和風速，而顯示器會顯示實際的環境濕度。

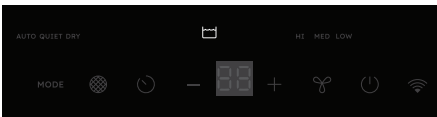

3. 使用睡眠模式時，按模式鍵並選擇睡眠模式。本產品全程將以低風速運轉並根據室內環境自動設定舒適濕度。

註: 在此模式中，無法手動設定濕度和風速，而顯示器會顯示實際的環境濕度。

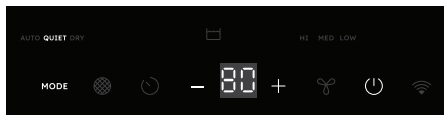

4. 使用乾衣模式時，按模式鍵並選擇乾衣模式。此模式中，可按“-”或“+”鍵選擇35%至85%的濕度值，讓房間維持在舒適濕度。按-或+鍵會改變5%濕度間隔選項。設定好理想的濕度後5秒，儀表會顯示實際的房間濕度。

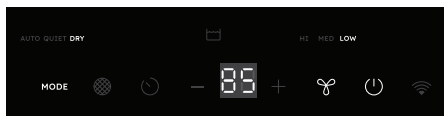

5. 使用乾衣模式期間，也可使用風速鍵改變高、中或低速。指示燈將顯示所選的設定。風速較高則除濕效果較快。



6. 使用連續除濕模式時，可在乾衣模式中按“-”鍵直到顯示CO。在此模式中，產品會持續運轉並僅顯示CO而非房間濕度。欲結束此模式，只要按“+”鍵即可跳出。



7. 定時功能可讓除濕機在0.5至24小時的範圍內定時開機或定時關機。若產品在運作中，設置定時將在設定的時間關機停止運作。若產品在關閉中，設置定時將在設定的時間啟動開始運作。

定時設定：先按定時鍵，然後輕點或按住“-”或“+”鍵調整時間，每點按一次可改變0.5小時間隔，最多到10小時，之後便會增減1小時間隔最多到24小時。設置完成後除濕機會倒數剩餘時間(8小時, 7.5小時, 7小時...)直到產品啟動或關機。定時開機時，風速和濕度將維持和之前設定相同。定時設定完成後，任何時候再次按壓定時鍵將停止定時功能。

定時開機/關機設定會一直倒數直到除濕機啟動或停止。一旦開機或關機後，必須重複上述步驟才能再度設定。



註：

- 設置定時設定之前，請確保產品已接上電源。
 - 設置定時開機之前，請先啟動除濕機，並設定好想要的運行模式。
8. 運轉250小時之後，濾網清潔指示燈將會亮起。請參照保養和清潔章節，取下並清潔濾網。當完成清潔並將濾網裝回後，按壓濾網清潔鍵便可重置並解除燈號。



9. 同時長按“-”與“+”鍵3秒能啟動或解除童鎖功能，顯示幕會顯示LC約5秒，控制面板會鎖住且無法改設定。



10. 本產品配有可透過APP上網的Wi-Fi晶片，可遠端控制並操作完整的功能。下載我們的App並遵守指示將產品連接網路。當連上網路後，"Wi-Fi"指示燈會亮起。



11. 本產品具有負離子功能。負離子僅可透過APP啟動和關閉，可下載APP至智慧型手機。一旦啟動負離子，可減少空氣汙染物質並更快速地淨化房間空氣。

12. 按 "⏻" 關閉本電器

註: 停電後，產品會記得最後設定並在復電後恢復跟之前相同的設定。



4.2 錯誤代碼

1. 若顯示幕出現 "AS" 或 "ES"，表示感測器故障，請聯繫伊萊克斯客服中心。

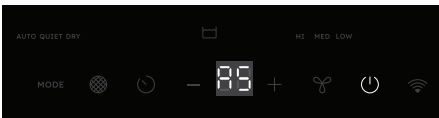

2. 若顯示幕出現"EC"，檢查下列運作狀態。電壓應該在110V±10%，環境溫度應該在5°C 到 35°C 之間。在正常運作環境下拔除電源再重新插入電源。如果 "EC" 碼持續，請聯繫伊萊克斯客服中心。



3. 若顯示幕出現"E4"，表示顯示板PCB和主控PCB之間的連線發生異常。請聯繫伊萊克斯客服中心。

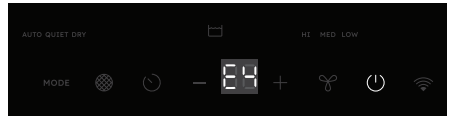

4.3 清空水箱

1. 清空水箱：

a. 當水箱滿水時，除濕機會停止運轉並且滿水指示燈“”會亮起。



b. 此時不要大力移動產品，否則水可能會灑出到地板。

c. 輕輕地抓住水箱兩側並取出水箱。

d. 請按下方圖示取出水箱並倒空水箱內的水。

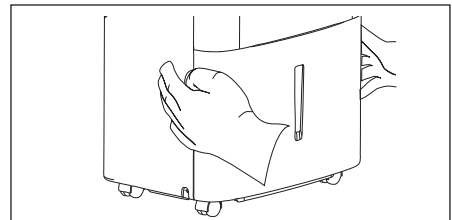

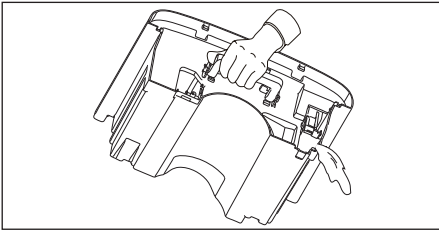
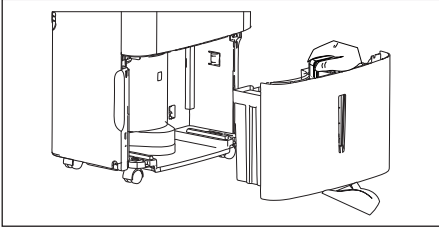
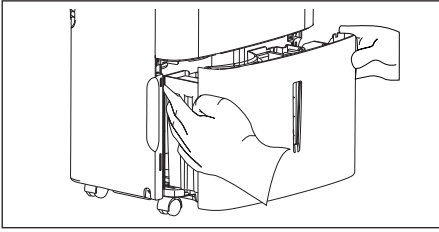

警告

請將水箱內的水倒掉，水箱內的水不可飲用。

- e. 將清空後的水箱放回除濕機，一旦確實置入，除濕機將重新啟動。
- f. 若水箱有放回正確的位置，您將會聽一聲喀聲。

若水箱滿水燈號沒有熄滅，檢查看看水箱的浮標是否在正確的位置上。

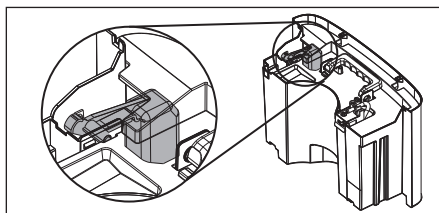

2. 連續排水

- a. 要使用連續排水功能，您需要排水管、排水轉接頭(非產品內附配件，若有需要請聯繫伊萊克斯客服中心)，以及可供排水的排水口。
- b. 鬆開產品背面的排水孔蓋。(圖1)

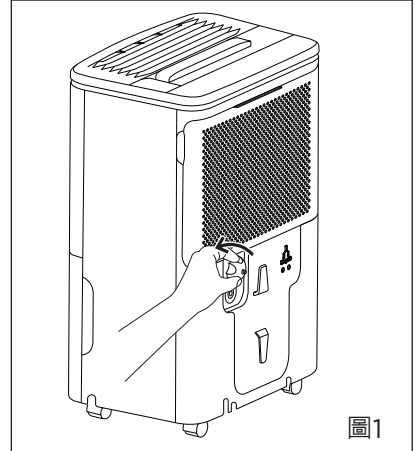

- c. 將排水轉接頭接到排水孔並旋緊轉接頭(圖2)

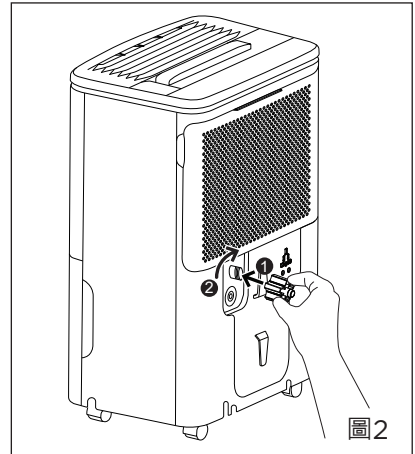

- e. 將排水管的一端連到排水轉接頭。確保排水管與轉接頭連接穩固避免漏水。(圖3)

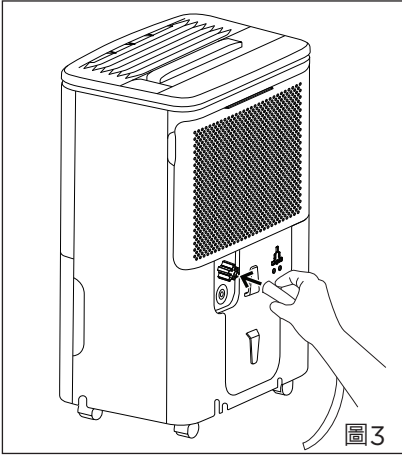

g. 將排水管的另一端接到比出水孔更低的排水口 (圖4)

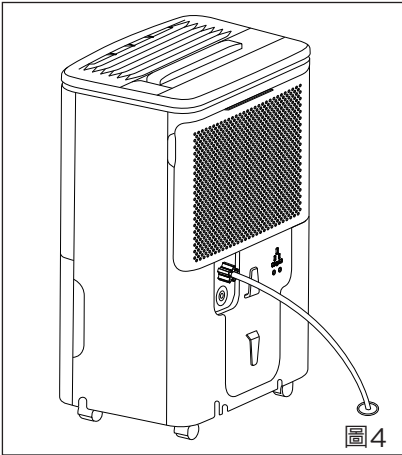

h. 在控制面板上選擇想要的濕度和風速設定以啟動持續排水功能。

註：

- 檢查排水管和排水轉接頭之間的接口，確保沒有小縫隙。
- 請確保水管沒有扭結或起伏。
- 請確保排水轉接頭拴緊到排水口以避免漏水。

5. 維護保養、清潔和存放

5.1 濾網

在正常運作狀態下每兩周清一次濾網。
若要取下濾網：

a. 打開機身背面濾網蓋

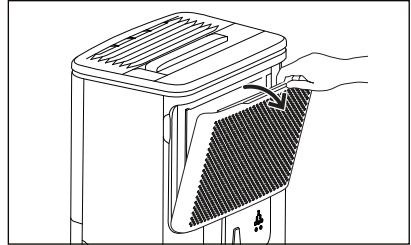

b. 壓住下圖顯示的卡榫從濾網蓋背面拆下濾網

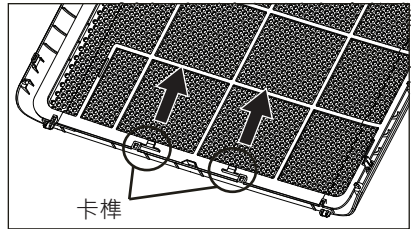

c. 以乾淨的水清洗濾網並陰乾
d. 重新安裝濾網

5.2 機身

- 用乾淨無油的軟布或微濕的軟布擦拭機身。
- 用配有小毛刷的吸塵器清潔進氣口格柵。

水箱

正常運作狀態下，每二周清潔水箱。

- 用溫水和清潔劑清潔水箱。

5.3 存放

- a. 拔除電器電源，利用產品背面的電源線收納勾整理電線。

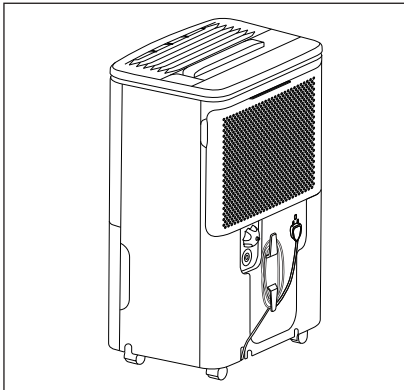

- b. 清空水槽並清潔乾淨。
c. 陰乾除濕機和所有配件。
d. 用塑膠袋包裝或裝回紙箱，然後將除濕機放置在涼爽乾燥位置。

5.4 正常聲音

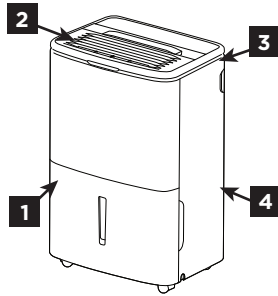

- 1 滴水聲**
除濕期間可能聽到滴水聲
- 2 洩濼聲**
除濕機上方可聽到風扇攪動的氣流聲
- 3 咯咯/嘶嘶聲**
正常運作期間可能會因為冷媒通過蒸發器而聽到“咯咯或嘶嘶”聲
- 4 高頻音**
高效壓縮機在除濕期間可能會出現高頻音

6. 疑難排解

在聯絡客服前，先查看這份清單可能會節省您的時間和花費。這份清單包括常見的非因組裝或材料瑕疵而出現的問題。

出現狀況	解決方案
除濕機沒有運轉	<ul style="list-style-type: none"> 牆上插座鬆脫，請穩固地將插頭推入牆壁插座中。 房屋的保險絲熔斷或無熔絲開關跳開。換成延時保險絲或重設無熔絲開關。 已達到設定的濕度。當濕氣已被移除到一定程度，除濕機會自動關閉。若希望移除更多濕氣，設定“連續除濕”功能。除濕機啟動後，重設操作面板到想要的設定。 沒有確實安裝好水箱。見“清空水箱”。 水箱內的水已滿。此時除濕機會自動關閉。清空水箱再放回原位置。 除濕機沒有啟動。啟動電源開機。 “”燈亮。取出水箱、清空水箱並確實地安裝回原位。

除濕機一直運轉	<ul style="list-style-type: none"> • 除濕機附近的門窗開放到室外。關閉所有對外的門窗。 • 除濕的區域範圍過大。跟經銷商確認適用坪數是否合適。 • 除濕機的空氣流動有受阻。進氣口格柵可能有髒汙。使用吸塵器的配件清潔進氣口格柵。見“維護保養、清潔和存放”。除濕機必須放置於沒有限制空氣流通到後方或前側出風口格柵之處。 • 最近才安裝或重啟除濕機。環境中的濕度越高，除濕機會運轉越長時間。 • 除濕機為“連續除濕”模式且一直維持在這個模式，將濕度設定值調高。
除濕機有運轉但房間不夠乾燥	<ul style="list-style-type: none"> • 濕度設定太高。調整濕度設定至較低濕度或選擇“連續除濕”保持最乾狀態。 • 剛安裝或重啟除濕機。室內空氣濕度越高，需要越久時間才能乾燥。 • 除濕機不夠潔淨導致無法運轉。出風口的空氣流動受阻。見“選擇使用位置” • 室溫太低。若室溫低於5°C機器便無法順利運轉。見“運轉條件”。 • 參照“除濕機一直運轉”底下的原因。
濾網背面金屬鱗片上結霜	<ul style="list-style-type: none"> • 剛啟動除濕機。這是因為冷媒迅速通過金屬鱗片而出現的正常現象。霜通常會在60分鐘內消失。 • 室溫太低。所有的款型都可以順利在5°C以上溫度的空間運轉。
風扇噪音	<ul style="list-style-type: none"> • 空氣通過除濕機。是正常聲音。
無法透過無線網路連到智慧手機或APP有狀況	<ul style="list-style-type: none"> • 請刪除APP並重新下載最新版本APP，重新再試一次看是否能解決。 • 請準備好除濕機型號、PNC、製造號碼、APP帳號、APP截圖或螢幕錄影，聯繫伊萊克斯客服中心。

7. 環境注意事項

請回收附有 ♻️ 符號的物料。回收包裝時，請將包裝放入適用的容器內。協助保護環境及人類健康，以及回收電力和電子器材的廢料。

請勿將標有 ♻️ 符號的器材，與家庭廢棄物一同棄置。請將產品運回您的本地回收設施，或聯絡您的所在地相關負責單位。

www.electrolux.com/shop

